

Aluminum Accessories Outside corner and Base

TECHNICAL DATA SHEET

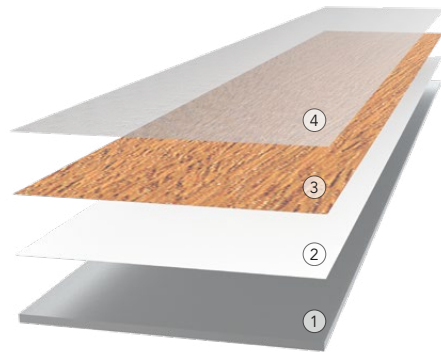
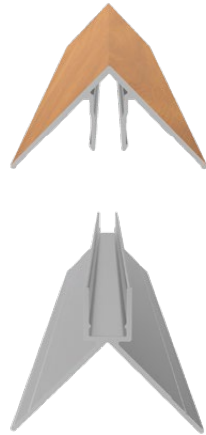

1. ALUMINUM

6063-T5 Aluminum extrusion 1.40 mm (0.055 in) thick recognized as the industry's first choice for its exceptional durability.

Accessory trim and base are joined together by snap fit allowing for seamless installation without visible screws.

Installation can be made both vertically and horizontally.

2. PRIMER COAT

Primer coat ($\pm 1,2$ mil. thick) applied to ensure perfect adhesion between aluminum and ink.

3. HD PRINTING

High-definition digital inkjet printing (± 1 mil. thick) is used to create photographic reproductions of a wide range of textures and outstanding color variations.

4. UV BARRIER

A protective clear coat ($\pm 1,2$ mil. thick) is applied to provide long-term protection against UV rays and fading.

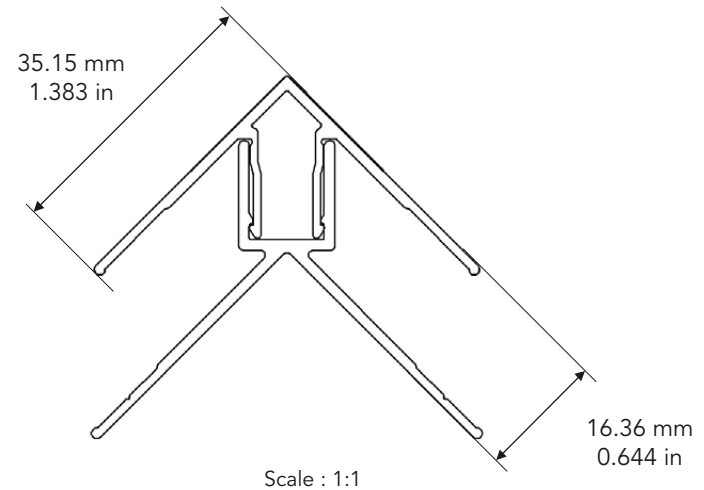

Tests & Certifications*

- . CAN/ULC S102 - Fire Resistance
- . CAN/ULC S114 - Fire Resistance
- . ASTM E84 - Fire Resistance
- . NFPA 285 - Fire Resistance
- . ASTM D6578 - Graffiti Resistance
- . ASTM G155 - UV Resistance
- . ISO 7895 / ASTM E330 - Wind Load
- . ISO 7895 - Impact Resistance
- . ASTM D3359 - Adhesion testing
- . ASTM D4060 (CS-17) - Abrasion Resistance
- . Florida Building Code (FBC) compliance
- . LEED V4

* see website for full details

Name :	Job # :	Color :	Date :
	Model : FA-OSC-1201	Product : Aluminum siding accessories	Initials :
	Length : 3.65 m / 12 ft	Material : Aluminum 6063-T5	
	Drawing by: JCC	Weight per piece (Trim cap) : 1.64 kg / 3.62 lbs	
	Date: 18-11-22	Weight total (Trim cap & Base) : 3.28 kg / 7.23 lbs	